



南京苏曼电子有限公司

Nanjing Suman Electronics Co., Ltd

CTE SERIES
CORONA Lab.

CTE-8000K
使用说明书

USER'S MANUAL

USER'S MANUAL

Please refer to the manual in detail before installing, operating and debugging.

安装，操作或调试设备前，请先详细阅读本说明

一. 概述

CTE 系列数码电子冲击机是采用具有自主知识产权的谐振型脉宽调制技术的全数字化产品，并在系列产品中应用了微电脑和模糊控制技术，使 CTE 系列产品获得了高可靠性、高效率、小体积和结构模块化。使用和维护简单方便。可对各种塑料薄膜或金属薄膜进行电晕处理。

1. BRIEF INTRODUCTION

The CTE-series computerized Corona-plus generators, utilizes DPC and PWM techniques, feature high reliability, high efficiency, minimized size and modular structure, simple & convenient to operate and maintain, realize corona treatment of various plastic film and metal film.

二. 设备

1. CTE-8000K 主机 (图 1)。
2. CTE-8000K 变压器箱 (图 3)。

2. EQUIPMENT

- 1.1 CTE-8000K generator unit (Figure 1)
- 1.2 CTE-6000K transformer unit (Figure 3)

三. 组件

3. COMPONENTS



图 1、主机面板
Figure 1 Generator front panel



图 2、主机背板
Figure 2 Generator rear panel



图 3、变压器
Figure 3 Transformer

1. 交流电源开关
2. 输出显示
3. 功率调节按钮
4. 排风窗口
5. 排风扇
6. AC220V 电源输入
7. 变压器接线平台
8. 主机接线柱
9. 高压输出接线柱
10. 地线接线柱
11. 加油孔
12. 泄气孔

1. AC power switch
2. Output display
3. Power adjustment button
4. Louver
5. Fan
6. AC220V power input
7. Junction box to transformer
8. Junction box to generator
9. High voltage output
10. Ground
11. Oil hole
12. Deflation hole

四、设备安装

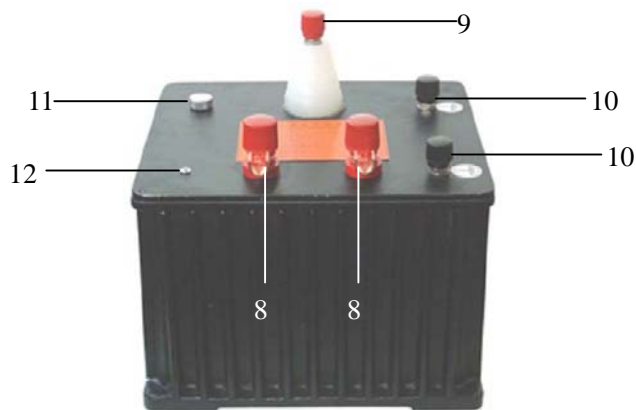
4. INSTALLATION

1. 主机和变压器的连接

4.1 Connect the generator to the transformer



图 4、主机和变压器箱的连接

Figure 4 Connect the generator to the transformer

接线要求:

- ◇ 变压器和主机的两根连接线连接没有极性,但不能和地接错。否则将损坏主机!
- ◇ 变压器和主机的连接导线规格请用大于 8mm², 并拉直排线。否则导线会消耗功率和发热而出现危险! 地线连接导线规格大于 1mm² 即可。
- ◇ 接线平台上的螺丝必须旋紧, 否则可能出现间歇工作或发热烧坏接线平台。

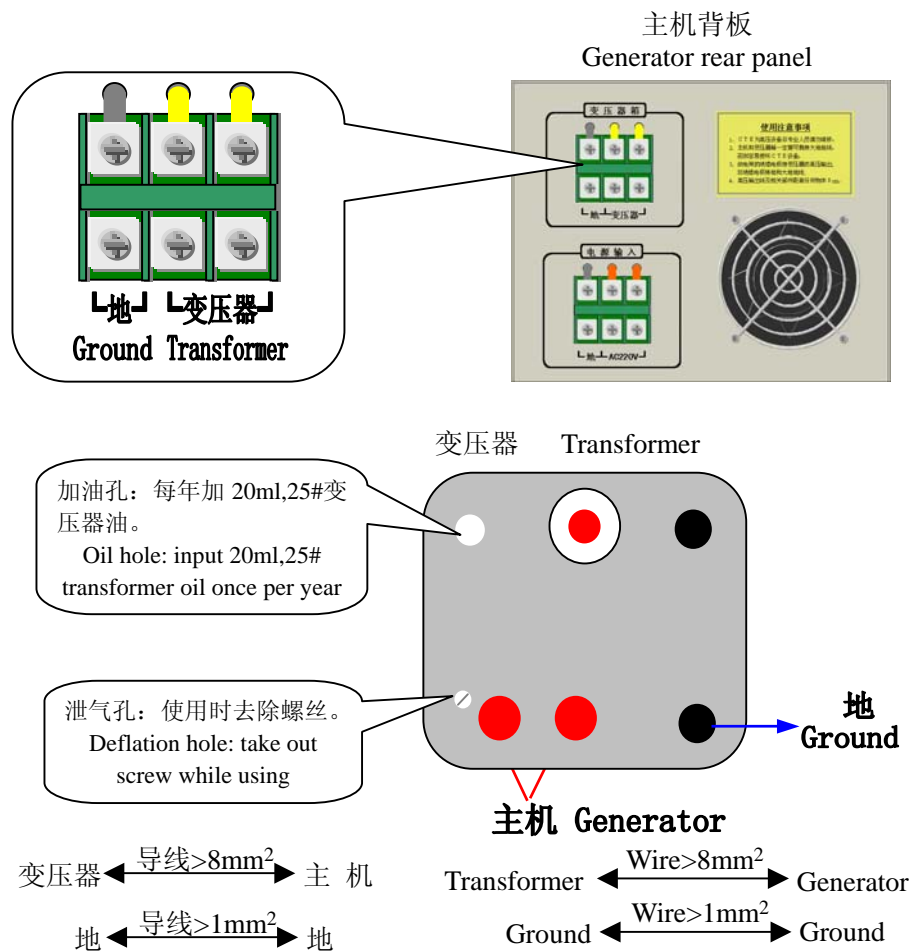
2. 变压器和放电架的连接



图 5、变压器和放电架的连接
Figure 5. Connect the transformer to corona-Plus treater station

Connecting Requirement

Connecting Requirement

- ◇ The two wires of transformer and generator are no polar, can not be connected to ground, otherwise the equipment will be damaged.
- ◇ The two wires of transformer and generator must be > 8mm² and must pull straightly so as to avoid danger due to power assumption and heating of wire, the ground wire will be > 1mm².
- ◇ The screw of junction box must be tightened to avoid occurring discontinuous operation or damaging the connecting due to heating.

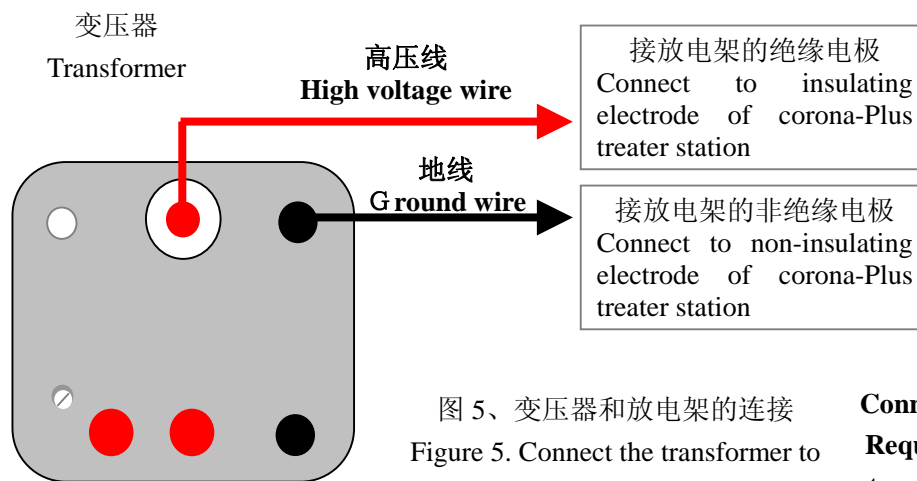
4.2 Connect transformer to discharging rack

接线要求:

- ◆ 地线需焊在焊片上再接在地线接线柱上。如果地线出现开路, 设备工作时将会将高压引至电晕设备, 使设备带电并损坏主机!!
- ◆ 接地请接大地地线。
- ◆ 高压线和其连接的相关部件与其它任何物体之间的距离需大于 80mm。否则可能出现放电, 致使设备出现间歇工作。
- ◆ 一定要认清放电架的绝缘电极和非绝缘电极。接反将损坏电晕设备。
- ◆ 所有接线应连接正确和可靠, 变压器箱和放电架之间的高压连线应尽可能的短。

- ◇ The ground must be welded on welding patch and then connecting to soldering terminal. Otherwise, the high voltage will be directed to corona equipment while operating, the generator maybe be damaged.
- ◇ Please connect to earth wire
- ◇ The distance between the high-voltage wire with its connecting relevant unit and other objects must be >80mm so as to avoid discontinuous operation due to discharge.
- ◇ Make clear the Insulating electrode and non-insulating electrode of corona-Plus treater station, connecting error maybe damage corona equipment.
- ◇ All the wiring must be connected correctly and reliably. The high-voltage connection between the generator and discharging rack must be as short as possible.

3. 主机和 AC220V 电源的连接

4.3 Connect the generator to AC220V power



图 6、主机和 AC220V 电源的连接

Figure 6. Connect the generator to AC220V power

接线要求:

- ◇ 请选用大于 6mm² 规格的导线，将电源 AC220V 可靠地连接至“电源输入”接线平台的“AC220V”。连接没有极性,但不能和地接错。
- ◇ 地一定要接大地地线。
- ◇ 接线平台上的螺丝必须旋紧，否则可能出现间歇工作或发热烧坏接线平台。

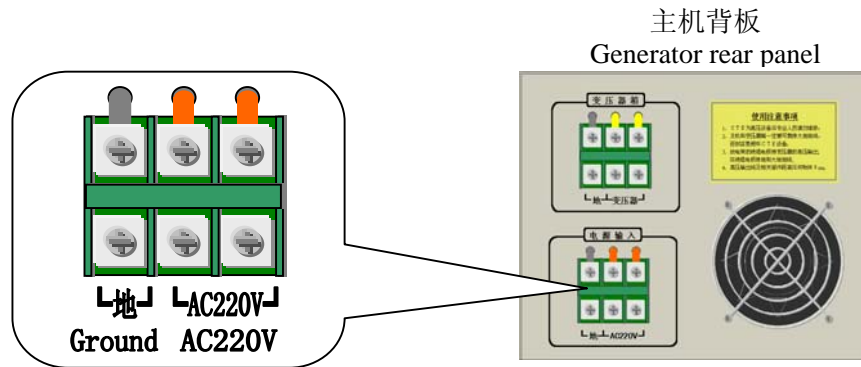
五、使用

1. 将电源开关①向上推至 ON 位置，电晕设备即可正常工作。在放电架上即会出现电晕放电。向下 OFF 位置，电晕设备停止工作。
2. 调节按键③，使输出功率达到要求的值。红键（UP）增加功率，绿键（DOWN）减小功率。
3. 每次开机，设备将保持上次关机时的功率值。

注意:

设备工作时，主机和变压器箱的风扇和排风窗口不能有物体遮挡。

Connecting Requirement

- ◇ The selected wire must be > 6mm², reliably connect AC220V power to “AC220V” of “POWER INPUT” junction box, the wiring is no polar, but can not be connected to the ground.
- ◇ Please connect to earth wire
- ◇ The screw of connecting must be tightened to avoid occurring discontinuous operation or damaging the connecting due to heating.

5. OPERATION

- 5.1 Turn the power switch ① to ON, the corona equipment will operate normally, occurring corona discharge on corona-Plus treater station, turn to OFF, the corona equipment will power off.
- 5.2 Adjust button ③ so that the output power reach the required value, red button (UP) is to increase power while green button(DOWN) is to decrease power.
- 5.3 The equipment will remain the power value of last powering off while operating.

NOTES

The fan and louver can not be sheltered by any object while operating.

中 文

六、规格

1. 型号: CTE-8000K
2. 频率: 15~20KHz
3. 电源: AC220V (±10%)
4. 处理宽度: 2m~4m
5. 主机尺寸: 250(W)×200(H)×360(D)mm
6. 主机重量: 4kg
7. 变压器尺寸: 350(W)×350(H)×350(D)mm
8. 变压器箱重量: 38kg
9. 主机和变压器之间的连线: <5m

七. 维护

1. C T E 系列设备为高压电源, 且主机内部的电路和 A C 220 V 电源不隔离, 非专业技术人员请勿维护和修理。
2. 每 6 个月清洁一次主机、变压器和放电架的灰尘。
3. 主机箱内如果间歇发出嘀…嘀…的报警声, 请检查高压输出的相关部件或硅胶辊是否有漏电或击穿。
4. 主机箱内如果连续的发出嘀…嘀…的报警声, 且放电架上无任何放电现象, 请更换主机内的主板或与销售商联系。
5. 有任何问题或维护技术资料可在公司互联网上得到帮助。

ENGLISH

6. SPECIFICATIONS

- 6.1 Model: CTE-6000K
- 6.2 Frequency: 15~20KHz
- 6.2 Power: AC220V (±10%)
- 6.3 Treatment Widths : 2m~4 m
- 6.4 Generator Dimension : 250(W) × 200(H) × 360(D)mm
- 6.5 Generator Weight: 4kg
- 6.6 Transformer Dimensions: 350(W)×350(H) × 350(D)mm
- 5.7 Transformer Weight: 38kg
- 5.8 Wire between generator and transformer: <5 m

6. MAINTENANCE

- 7.1 CTE series equipment is high-voltage power, and the internal circuit of generator and AC 220V is not isolated, please DO NOT self-maintain or repair.
- 7.2 Clear up the dirt in the generator, transformer and corona-Plus treater station once per 6 months.
- 7.3 If occurring di-di alarm discontinuously in the generator, please check whether occurring leakage or breakdown of the relevant unit of high-voltage output or silica gel roller.
- 7.4 If occurring di-di alarm continuously in the generator, and no discharging on corona-Plus treater station, please change the main-board in the generator or contact with the salesman.
- 7.5 please log on <http://www.coronalab.net> if you need maintenance technical information or have any questions.

单 位: 南京苏曼电子有限公司
单位地址: 南京市堂子街 41 号通宇大厦 7 楼
电 话: 025-86592881
传 真: 025-86592891
邮政编码: 210004

Nanjing Suman Electronics Co.,Ltd
Tel: +86-25-86592881
Fax: +86-25-86592891
E-mail: sm@coronalab.net
<http://www.coronalab.net>